

### VDI SAFETY

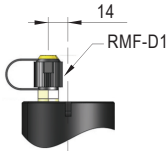

The TPCB 4500 model is also available equipped with RMF-D1. (TPCB 4500x...C-Linked)

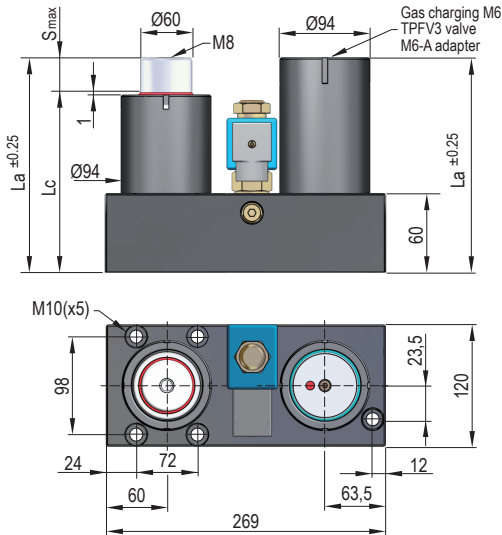

Code	Smax mm	La mm	Lc mm	Fa daN	90% F daN	100% Fc daN	P Bar
TPCB 4500x12	12	140	128	4500 ±5% (20°C)	4590	4630	150 (20°C)
TPCB 4500x25	25	166	141		4815	4890	
TPCB 4500x38	38	192	154		4965	5060	
TPCB 4500x50	50	216	166		5065	5175	
TPCB 4500x63	63	242	179		5140	5265	
TPCB 4500x80	80	276	196		5220	5355	
TPCB 4500x100	100	316	216		5285	5435	
TPCB 4500x125	125	366	241		5345	5505	

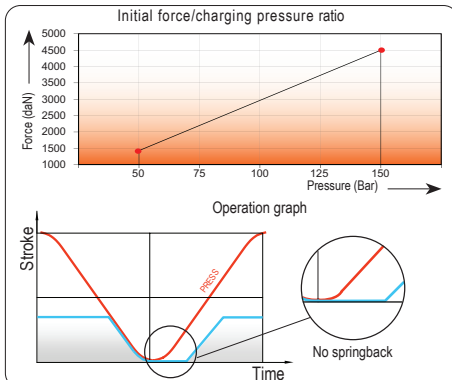

Pressure medium	Nitrogen (N <sub>2</sub> ) / Oil
Max. charging pressure	150 Bar
Min. charging pressure	50 Bar
Rod seal area	28,27 cm <sup>2</sup>
Operating temperature	0°C - 60°C
Force increase by temperature	0,33 %/°C
Max. stem speed	15 - 22 m/min
Max. recommended strokes/min	8 - 20* spm



### Required information

Working stroke	(mm)
Press speed	(m/min)
Maximum production rate	(spm)
Working pressure	(bar)

\* Maximum rate will depend on working parameters

